



**ekostarter.pl**

TEL. 509 677 350  
TEL. 39 904 12 09  
sklep@ekostarter.pl

**ALTERNATORY I ROZRUSZNIKI  
DLA PRZEMYSŁU I ROLNICTWA**

DANE TECHNICZNE, ZASTOSOWANIA, WYMIARY



## ROZRUSZNIK DAEWOO / TYP D2



**Cena :**

**Chwilowy brak ceny**

Nr katalogowy : **RR2502**

Dostępność : **Dostępny**

**ROZRUSZNIK**

**24V, 4.5 kW**

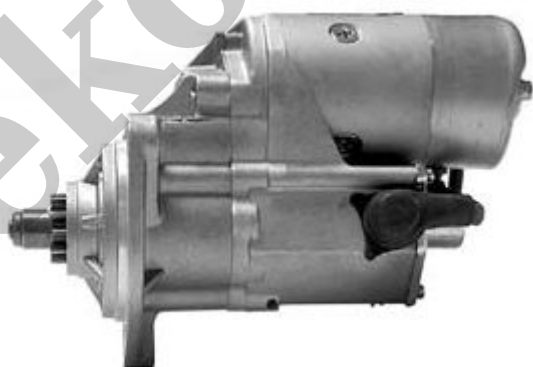

**ZASTOSOWANIE**

**MASZYNY DAEWOO - RÓŻNE MODELE**

DAEWOO: 65.26201-7044;

POONG SUNG: 03112-7021

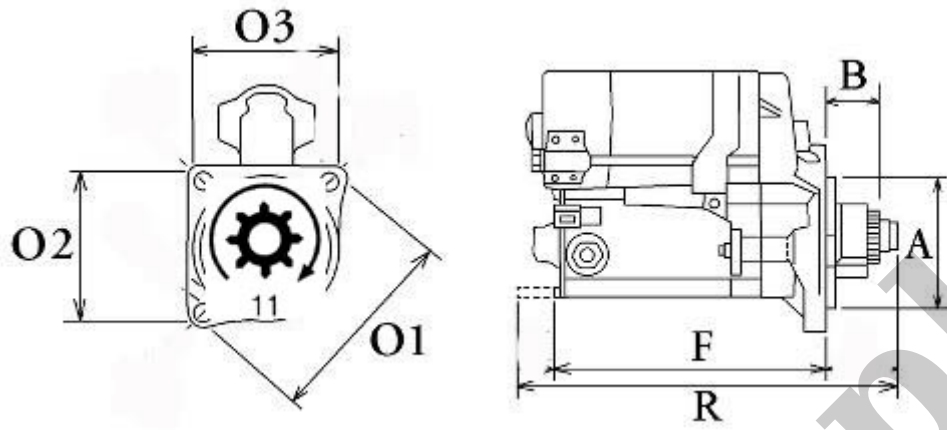

WYMIARY	mm
O1	134,75 mm
O2	111 mm
O3	110,40 mm
A	105 mm
B	42,30 mm
F	231,50 mm
R	293,50 mm

ekostarter.pl